

Technical sheet :

MLT 630-105



Capacities		Metric	Imperial
Max. capacity	Q	3000 kg	6614 lbs
Max. lifting height	h3	6.1 m	20 ft
Max. outreach	l4	3.34 m	10 ft 11 in
Reach at max. height		0.9 m	2 ft 11 in
Breakout force with bucket		5840 daN	5840 daN
Weight and dimensions			
Unladen weight (with forks)		7000 kg	15432 lbs
Ground clearance	m4	0.35 m	1 ft 2 in
Wheelbase	y	2.69 m	8 ft 10 in
Overall length to carriage (with hitch hook)	l11	4.78 m	15 ft 8 in
Front overhang		1.25 m	0.049 in
Overall width	b1	2.13 m	7 ft
Overall cab width	b4	0.95 m	3 ft 1 in
Overall height	h17	2.37 m	7 ft 9 in
Tilt-down angle	a5	133 °	133 °
Tilt-up angle	a4	13 °	13 °
External turning radius (over tyres)	Wa1	3.68 m	12 ft 1 in
Standard tyres		Alliance - A580 - 405/70 R24 152A8	Alliance - A580 - 405/70 R24 152A8
Drive wheels (front / rear)		2 / 2	2 / 2
Steering wheels (front / rear)		2 / 2	2 / 2
Performances			
Lifting		6.5 s	6.5 s
Lowering		5 s	5 s
Extension		5.4 s	5.4 s
Retraction		3 s	3 s
Crowd		3.4 s	3.4 s
Dump		2.7 s	2.7 s
Engine			
Engine brand		Deutz	Deutz
Engine norm		Stage IV	Stage IV
Engine model		TCD 3.6 l	TCD 3.6 l
Number of cylinders - Capacity of cylinders		4 - 3621 cm ³	4 - 220.97 in ³
I.C. Engine power rating / Power (kW)		101 Hp / 74.4 kW	101 Hp / 74.4 kW
Max. torque / Engine rotation		410 @1600 tr/min	410 @1600 tr/min
Drawbar pull (Laden)		6800 daN	6800 daN
Reversible fan		Standard	Standard
Engine cooling system		4 radiators (water + intercooler + hydraulic oil + transmission oil)	4 radiators (water + intercooler + hydraulic oil + transmission oil)
Transmission			
Transmission type		Torque Converter	Torque Converter
Gearbox		Powershuttle	Powershuttle
Number of gears (forward / reverse)		4 / 4	4 / 4
Max. travel speed (may vary according to applicable regulations)		40 km/h	24.9 mph
Differential lock		Limited slip differential on front axle	Limited slip differential on front axle
Parking brake		Manual	Manual
Service brake		Oil-immersed multi-discs on front & rear axles	Oil-immersed multi-discs on front & rear axles
Hydraulics			
Hydraulic pump type		Gear Pump	Gear Pump
Hydraulic flow - Pressure		104 l/min - 250 Bar	104 l/min - 17 PSI
Flow sharing distributor		Option	Option
Tank capacities			
Hydraulic oil		94 l	20.68 gal
Fuel tank		78 l	17.16 gal
Diesel Exhaust fluid (AdBlue® type)		13 l	2.86 gal
Noise and vibration			
Noise at driving position (LpA) tested following NF EN 12053 norm		75 dB(A)	75 dB(A)
Environmental noise (LwA)		105 dB(A)	105 dB(A)
Vibration to whole hand/arm		< 2.50 m/s ²	< 2.50 m/s ²
Miscellaneous			

Miscellaneous			
Safety tractor homologation / cabin homologation		Safety tractor homologation - Cab ROPS - FOPS Level 2	Safety tractor homologation - Cab ROPS - FOPS Level 2
Controls		JSM	JSM

Options / Finishing

S : Standard / O : Optional / - : Not available

	Classic	Premium	Elite
General			
Self cleaning air prefilter	S	S	S
Automatic wheel alignment	O	O	S
Additional fuel tank (42 l)	O	S	S
Automatic rotating towing hitch on counterweight	O	O	O
Ladder hitch with choice of hooks	O	O	O
Hydraulic pick-up hitch - low position	O	O	O
Manual rotating towing hitch	S	S	S
Comfort			
Low frequency air suspension cloth-covered seat (GRAMMER)	O	O	-
Mechanical cloth-covered seat (GRAMMER)	S	-	-
Air suspension cloth-covered seat (GRAMMER)	O	S	-
Tuner car radio (50 W)	S	-	-
Bluetooth USB car radio with extra microphone (100 W)	O	O	S
"Harmony" screen	S	S	-
"Vision" display	O	O	S
Air conditioning with manual adjustment	O	S	-
Air conditioning with automatic adjustment	O	O	S
Hydraulics			
Hydraulic attachment locking	O	O	O
1 pair of pre-fitted Double Action rear hydraulic couplers	O	O	O
Electricity / Safety			
Audio warning on reverse	O	O	O
Front and rear work lights on cab (x4: 2 front + 2 rear)	S	-	-
Front and rear LED work lights on cab (x4 : 2 front + 2 rear)	O	S	S
Extra front wiper	O	S	S
Electric mirror with de-icing	O	O	S
LED + (4 additional work lights)	O	O	O
Boom Work Lights (on fixed part) (x2)	O	O	O
Audio warning on reverse movements	O	O	O
Boom options			
Easy Connect System (E.C.S.)	S	S	S
Continuous flow hydraulics	O	O	S
Return pipe to hydraulic oil tank	O	O	O
Electrovalve for 2 hydraulic functions (on boom head)	O	O	O
Engine & Filtration			
Auto reversing fan	S	S	S
Safety/Security options			
Hydraulic trailer brake	S	S	S

Load chart

Rough terrain load chart (EN 1459 B) Metric

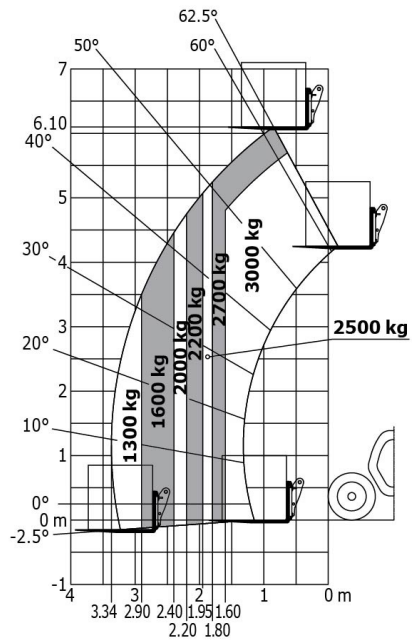

Dimensional drawing

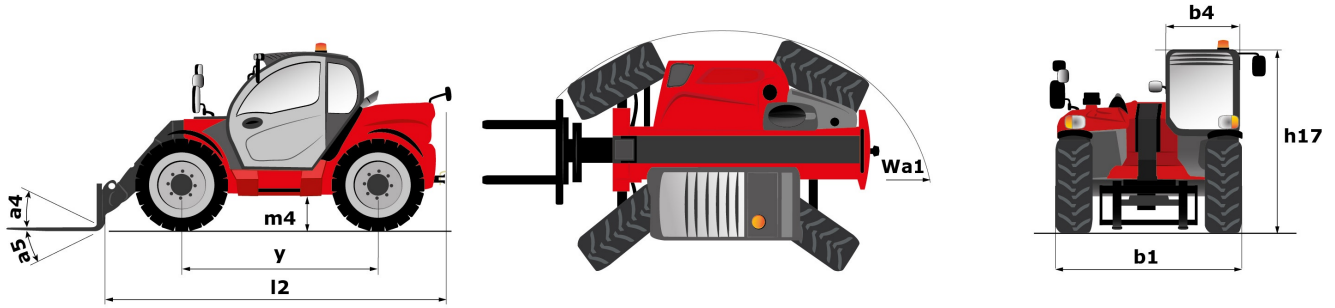



Siège Social
430 rue de l'Aubinière - 44150 Ancenis Cedex - France
Tel: +33(0)2 40 09 10 11 - Fax: +33 (0)2 40 09 10 97
www.manitou.com



This brochure describes versions and configuration options for Manitou products which may be fitted with different equipment. The equipment described in this brochure may be standard, optional or not available depending on version. Manitou reserves the right to change the specifications shown and described at any time and without prior warning. The manufacturer is not liable for the specifications given. For more information, contact your Manitou dealer. Non-contractual document. Product descriptions may differ from actual products. List of specifications is not comprehensive. The logos and visual identity of the company are the property of Manitou and may not be used without authorisation. All rights reserved. The photos and diagrams contained in this brochure are provided for information only.

MANITOU BF SA - Limited company with board of directors - Share capital: 39,547,824 euros - 857 802 508
RCS Nantes